

FRANKLIN *Sheehan*

n-96-01
TL-1-563

INTERSTATE MOTOR CARRIER NOISE EMISSION COMPLIANCE REGULATIONS

Issued on
September 12, 1975
Effective Date
October 15, 1975



U.S. DEPARTMENT OF TRANSPORTATION
Federal Highway Administration
Bureau of Motor Carrier Safety

Title 49—TRANSPORTATION

Chapter II - Federal Highway Administration, Department of Transportation

Part 325 - Compliance with Interstate Motor Carrier Noise Emission Standards

CONTENTS

	Page
Preamble to Rule	1
Subpart A	
General Provisions	10
Subpart B	
Administrative Provisions	11
Subpart C	
Instrumentation	12
Subpart D	
Measurement of Noise Emissions; Highway Operations	12
Subpart E	
Measurement of Noise Emissions; Stationary Test	15
Subpart F	
Correction Factors	18
Subpart G	
Exhaust Systems and Tires	21

Title 49—Transportation

CHAPTER II—FEDERAL HIGHWAY ADMINISTRATION, DEPARTMENT OF TRANSPORTATION

[Docket No. MC-62; Notice No. 75-17]

PART 325—COMPLIANCE WITH INTERSTATE MOTOR CARRIER NOISE EMISSION STANDARDS

Final Regulations on Compliance with Standards

• Purpose: The Director of the Bureau of Motor Carrier Safety is issuing these final regulations for the purpose of establishing measurement procedures and methodologies for determining whether commercial motor vehicles conform to the Interstate Motor Carrier Noise Emission Standards of the Environmental Protection Agency (40 CFR 202). •

INTRODUCTION

On October 21, 1974, the Acting Administrator of the Environmental Protection Agency (EPA) issued final regulations establishing standards for maximum external noise emissions of motor vehicles having a gross vehicle weight rating (GVWR) or a gross combination weight rating (GCWR) of more than 10,000 pounds that are operated by commercial motor carriers engaged in interstate commerce (39 FR 38208). Those regulations were issued under the authority of section 18 of the Noise Control Act of 1972. Section 18 of the Noise Control Act of 1972 also directs the Secretary of Transportation to promulgate regulations to ensure compliance with the EPA's standards. The Secretary is required to carry out the regulations through the use of his powers and duties of inspection and enforcement authorized by the Interstate Commerce Act and the Department of Transportation Act. Those two statutes vest in the Department of Transportation the responsibility for issuing and enforcing the Federal Motor Carrier Safety Regulations.

On February 28, 1975, the Director of the Bureau of Motor Carrier Safety (BMCS) published in the FEDERAL REGISTER (40 FR 8658) a text of proposed regulations establishing measurement methodologies for determining whether commercial motor vehicles conform to the Interstate Motor Carrier Noise Emission Standards published by the EPA at 40 CFR 202. The purpose of this order is to establish final regulations which detail those measurement methodologies.

The objective of the regulations detailed herein is to prescribe the manner in which commercial motor vehicles will be inspected and examined, and their

performance will be monitored and measured, to determine whether they conform to the EPA standards. Those standards become effective on October 15, 1975, and, as noted above, are applicable only to motor vehicles with a GVWR or a GCWR of more than 10,000 pounds which are operated by interstate motor carriers. The enforcement regulations contained herein also become effective on October 15, 1975.

SUMMARY OF COMMENTS

Thirty responses were filed to the docket on this subject. The BMCS has carefully reviewed and considered all of those comments. A summary of the major points raised in those comments along with the Bureau's disposition of each follows:

(1) Several respondents suggested that the final rule should not be made applicable to older vehicles, thereby eliminating the potential of having to retrofit or improve the maintenance of some of these vehicles to meet the noise emission requirements.

Both the EPA and the BMCS were specifically directed by the language of section 18 of the Noise Control Act of 1972 to develop noise emission standards applicable to the operations of motor carriers engaged in interstate commerce regardless of the date of manufacture of the vehicle. The applicability section of the EPA standards reflects that mandate and the BMCS may not alter or limit the scope of that applicability.

(2) Several respondents cited the possibility of a vehicle being able to pass one test, say a low speed pass-by-test, and yet fail another, say the stationary run-up test. They suggested a number of alternatives, such as using pass-by tests only for screening purposes while using stationary tests as the sole enforcing method. Another suggested that a successful demonstration that a vehicle could pass one of the three vehicle tests, should nullify a failure, by that same vehicle, of either of the other two tests.

EPA's noise emission standards clearly intend that the three vehicle tests that are specified be equally applicable to the operation of a motor vehicle subject to the standard. The BMCS regulations, therefore, merely specify the test procedures that are necessary when using each of these three tests.

BMCS is not at liberty to decrease the flexibility designed into the EPA standards by limiting enforcing agencies to only one of the specified tests.

(3) Numerous comments were submitted relative to the "need" for a tol-

erance when making measurements for enforcement purposes. Several respondents submitted data which were intended to document the imprecision of motor vehicle noise emission measurements. Variables, such as ambient temperature and atmospheric pressure, wind, sound measuring equipment variations, terrain at the measuring site, the presence of reflecting surfaces, such as curbs and guardrails in or around a site, and the potential for human error were cited as being factors which could influence noise measurements.

The Director is faced with a set of conflicting requirements with regard to this issue. On one hand is the need and desire to maintain the intended stringency of the EPA standard by not decreasing its effectiveness with the addition of a mandatory tolerance. On the other hand, there is the realization that unless some flexibility is built into any enforcement measurement program, the probability is high that the rule will be improperly enforced and potentially inequitable.

The Director does not dispute the fact that the above-cited variables can, and do, affect motor vehicle noise emission measurements. What can be argued is the degree to which the presence or absence of these variables adversely affects a measurement in a practical sense.

It is highly improbable, for example, as one respondent suggested, that the positive tolerances implicitly allowed for both sound level meters (in ANSI S1.4-1971) and for coupler type calibrators (in ANSI S1.3-1971) could consistently combine to the disadvantage of fleet operators, thereby causing the meter readings to always be 3 dB higher than they should be. Theoretically this could happen, but practically and statistically it is a remote possibility.

If this logic were applied from the opposite viewpoint, it could be argued that a 3 dB penalty should be added to all readings since it is equally probable that all measured readings could be consistently 3 dB low. Mandating, as was suggested, that a 3 dB tolerance be added to all measurements to take into account this possibility alone would represent an irresponsible denigration of the intended stringency of the EPA standard.

Other respondents disputed the validity of allowing objects such as curbs and guardrails within a measurement site. Data were also submitted to show that high or low ambient temperature extremes can affect the levels measured.

One respondent cited the intent of Congress that there be uniform national standards in this area as being sufficient

justification for a mandatory tolerance, since to do otherwise would potentially result in vehicles being cited in violation in one State and not in violation in another.

Some of the comments have pointed out combinations of conditions permitted under these regulations (i.e., reflecting surfaces just outside the required clear zone) which, under other test procedures (for example, those of the California Highway Patrol) would call for 1 dB corrections. Such corrections are not specified in these regulations. Other comments submitted to the EPA docket for that agency's standard, detailed the extraordinary circumstance of focusing reflecting surfaces (e.g. buildings behind and flanking the clear zone) which could increase measured sound levels by several dB.

The Director has carefully weighed these arguments and has decided against mandating a specific tolerance. He does so, however, with the knowledge that enforcement agencies will have to clearly demonstrate that a violation of the standard was measured, (i.e., that the specified level of the standard was exceeded by a meaningful minimum amount) and that the measurements were made with sufficiently accurate equipment in a sufficiently controlled environment to verify that the standard was exceeded under the actual test conditions. In order to control as many of these variables as possible, one would have to choose a site having perfectly flat ground within and beyond the test site, uniform short grass in the case of a pass-by test, and paved asphalt or concrete for a stationary test, and absolutely no reflecting surfaces within or beyond the test site area.

Measurements would ideally be made only at temperatures of approximately 55° to 85° F (13° to 29.4° C), under standard atmospheric pressure, with no wind present. The site would ideally be in a rural location with extremely low background noise and low traffic volume. Measurements made on an individual vehicle would be taken with no other vehicles anywhere near the test site area.

Under the above conditions, and using Type 1 sound level measuring equipment, an enforcing agency could possibly cite as violations any vehicle measured at 1 decibel in excess of the level specified in the EPA Standard and be secure in the knowledge that their citation would be technically valid. However, noise measurements are rarely, if ever, made at sites such as the one described above.

In an effort to provide the widest geographic coverage possible, the Director has adopted an enforcement proce-

sure that expands the potential number of inspection sites available to a higher number than would otherwise be possible if only "clean" test sites, from an acoustical measuring point of view, were utilized. What results is a trade-off. Measuring now becomes possible for a wider range of locations and conditions but the potential for variance slightly increases.

The regulation as written guards against many of the potential errors by including, among other things, such requirements as the 6 dB "rise and fall" requirement for pass-by tests and ground surface correction factors. The combined effects of these corrections do not guarantee with total certainty in each and every case, that other variables are not present to cause a meter reading to be high.

Enforcing agencies, therefore, must consider these uncertainties when enforcing the motor carrier noise emission standards. However, the application of a tolerance need not be mandatory in each and every case, as for example, in the situation where a carrier's vehicles are consistently measured at levels slightly above the allowable level, but within the tolerance range, and no corrective action on the part of the carrier has been evidenced. Enforcement agencies should inform the carrier of the situation, strongly recommending that the carrier take appropriate corrective actions to reduce the sound level of his vehicles safely below the standard before further equipment degradation produces actual violations. The possibility that "noise traps" might emerge as a result of the issuance of these regulations was clearly on the minds of many respondents as they addressed themselves to this issue. The Director's position on this issue will not totally satisfy them in that a lack of mandatory tolerance leaves some discretion to an enforcing agency. The narrow range within which enforcement agencies are to operate guards against the potential of noise traps to the extent feasible. The State and local agencies that currently enforce noise emission regulations generally do so in a professional and equitable manner. There is no reason to believe that these agencies or any other agencies enforcing noise regulations in the future will begin, with the issuance of these regulations, to do otherwise.

The BMCS, in the immediate future, will be issuing guidelines that will cover some of the more common pitfalls in noise emission measurements. When published, this document will be available

to interested parties. The subject of measurement tolerances will be covered in that document.

(4) The EPA requested that the Bureau clarify which sections of this regulation must be incorporated by a State or local government wishing to adopt the Federal standards while complying with the "preemptive" clause contained in section 18(c) (1) of the Noise Control Act.

Clearly, the measurement methodologies contained in subparts C through G of these regulations constitute the second part of the Federal regulatory program of interstate motor carrier noise control. These subparts assure the uniform implementation and enforcement of the EPA noise emission standards. Subparts A and B need not be incorporated since they contain certain aspects which only pertain to the actions of Federal enforcing agents. The DOT is researching means to enhance the enforceability of the EPA standards. These research results, in addition to Federal, State, and local experience gained with the present regulations, will serve as bases for future amendments to these regulations.

(5) One respondent requested that proposed § 325.1(b) be modified to make it clear that the Bureau had no jurisdiction to enforce noise emission regulations on vehicles being operated in intrastate commerce.

Sections 18(a) (1) and (2) of the Noise Control Act authorize the EPA to set "... limits on noise emissions resulting from operation of motor carriers engaged in interstate commerce . . ." Based on this language, EPA has promulgated final noise emission standards which clearly apply to both the intrastate as well as the interstate, operations of interstate motor carriers. Those standards do not apply to the wholly intrastate operations of intrastate motor carriers.

The role of the Department of Transportation, defined by section 18(b) of the Noise Control Act is to "... promulgate regulations to insure compliance with standards promulgated by the Administrator under this section."

Recognizing that EPA has the authority to set noise emission standards applicable to all operations of interstate motor carriers, it would be contrary to the Congressional intent for the Director to promulgate compliance regulations applicable to only some operations of those motor carriers.

The Bureau's activities are further defined by the statement that, "The Secretary of Transportation shall carry out such regulations through the use of his powers and duties of enforcement and

inspection authorized by the Interstate Commerce Act and the Department of Transportation Act." It is apparent that the phrase "... powers and duties of enforcement and inspection ..." as used in the above context does not carry with it the jurisdictional limitations referred to by the respondent. Rather, it expands upon the safety functions of the Bureau to now include jurisdiction over motor carrier noise emission enforcement activities. The jurisdiction attendant with these activities is derived from the Noise Control Act, not the Interstate Commerce Act, since this latter act addresses only the safety related activities of the Bureau.

To adopt the respondent's jurisdictional interpretation, pushed to its logical extreme, could result in the spurious argument that the Bureau could not enforce any EPA noise standard because it is not a safety standard. This was obviously not the intent of Congress. Accordingly, the applicability of these enforcement regulations extends to all the vehicles operated by a motor carrier who engages in interstate commerce.

(6) Several commenters suggested the need for additional language in § 325.1 (c) (3) and (6) to prohibit the intentional thwarting of noise measurements by sounding warning devices or by operating, at speeds greater than 5 mph (8 kph), auxiliary equipment designed for use at speeds less than 5 mph (8 kph).

The two sections in question, as originally proposed, were incorporated directly from the EPA noise emission standard. The exemptions were obviously added by EPA to preclude the possibility of inadvertently penalizing an operator for an otherwise justifiable and necessary act. They were not intended to provide a means for escaping noise emission measurements. Accordingly, these two sections have been modified to include measurement of sound generated by otherwise exempted sound sources if such sources are operated in an attempt to avoid enforcement measurements.

(7) Several suggestions were offered to change the time that an enforcement officer or agent may inspect a carrier's vehicles from "anytime" to "any reasonable time." Bureau safety investigators have never been intentionally unreasonable about the time they inspect the properties of motor carriers. Accordingly, it does not appear necessary to add the requested language.

(8) One respondent questioned the seemingly loose tolerances proposed for calibrators.

The tolerance proposed for calibrators was incorporated directly from ANSI S1.13-1971, *Methods for Measurements of Sound Pressure Levels*, for field type measurements. Since this is a recognized document for this subject area, its inclusion is appropriate herein. To further emphasize this fact, the final regulation has been modified to incorporate by reference the requirements of this document rather than specifying a specific tolerance.

(9) The time intervals between sound level meter calibration checks, specified in proposed § 325.25, were questioned by several respondents as being too burdensome and potentially unnecessary. Several wording changes were suggested by these commenters. It was also suggested that microphone coupler type calibrators be specifically required.

The respondents on this issue indicate that repeated calibrations, relatively close in time, are unnecessary since the meter rarely drifts from its calibrated level after it has been set up. Accordingly, the section in question has been modified to incorporate fewer calibration checks once the meter stability has been established after initial set-up.

A requirement for coupler type calibrators has also been incorporated in the final rule, since this type of calibrator checks the function of both the microphone and the internal electronic systems of a sound level measurement system.

(10) It was suggested that the attenuation properties specified for windcreens in § 325.27 of the proposed regulation would place an unnecessary burden of proof on enforcing agents, and should, therefore, be dropped. The attenuation limits proposed were those specified by several sound level meter manufacturers as being the attenuation limits of the windcreens they currently offered for sale. It was the intention of the Bureau, in its proposal, to ensure that windcreens of the type and quality currently manufactured and in use, would continue to be the type used for enforcement purposes. Accordingly, the section has been reworded to reflect that intention.

Proposed §§ 325.33 and 325.53, which deal with site characteristics, drew the most comments and criticism from respondents. The comments were almost equally split in sentiment. State and local enforcement agencies generally indicated that the language, as proposed, was too legalistic, too precise in tone and would

tend to hinder enforcement efforts by severely limiting the number of sites available for measurements and by creating evidential difficulties. Counter arguments were raised by users and manufacturers to the effect that the restrictions were too few, and that too many objects, such as curbs and guardrails, would be allowed within a site, thus potentially causing noise readings to be high. Specific objections were raised by both groups about 1) the allowable distances between the microphone and the vehicle, 2) clear zone distances, 3) allowable objects within a test site, specifically guardrails and curbs, 4) ground surface correction factors, and 5) topography at the measurement site.

Sufficient experience has been gained by State and local governments to indicate that noise emission measurements can be made effectively and equitably at typical highway locations. Relatively few, if any, of the sites used resemble the "engineering" type of test site that was suggested to be made mandatory by several respondents.

In view of the previous discussions on measurement tolerances and the need for flexibility when choosing sites, little has been changed in this section from that which was proposed. The section has been reworded in an effort to make it clear that it will not be necessary to conduct topographical surveys of sites to ensure precise measurements of microphone heights and distances, and topography of the ground within the test site, relative to the roadway. The open site requirements relative to tunnels and overpasses have been extended to 200 feet (62 m) on the suggestion that this will totally preclude the possibility of this source of noise enhancement, but in so doing very few potential measurement sites will be excluded.

The distance correction factors have not been modified to allow measurements at distances less than 35 feet (10.7 m), nor more than 83 feet (25.3 m), since the sound propagation assumptions used to generate correction factors for these lesser or greater distances are not undisputed. Several factors cause measurements taken at distances closer than 35 feet to be viewed suspiciously. Among these are 1) near field acoustical effects not generally seen at greater measurement distances, 2) the fact that at close distances a passing truck can no longer be even approximated to be a point source of noise, thereby invalidating some theoretical source propagation models, and 3) the fact that reflection effects from

the ground tend to become exaggerated at close-in measurement distances. These factors, heretofore, have combined to cause measurements at these closer distances to be highly unpredictable. Accordingly, until further data can be obtained relative to this issue, the Director has opted not to expand the range of allowable measurement distances.

New definitions have been added to define "relatively flat" as it applies to site topography, "traffic railings," and "hard" and "soft" as they relate to the ground surface within the site. For the sake of uniformity and consistency of enforcement, the last two definitions have been specified in absolute, quantitative terms. While it is realized that the break point between a "hard" and "soft" site, as defined herein, is arbitrary, it is presented in the interests of specificity, rather than as being a scientifically determined certainty. Due to this fact, care should be exercised when choosing sites to try to avoid those which are marginally "soft" or "hard."

(12) Several respondents pointed out the potential for confusion arising out of the use of the proposed tables of ambient sound levels.

In response to these comments, the ambient noise level tables have been dropped and a new table which lists maximum allowable emission levels has been included in the regulation, and ambient sound levels are now specified as having to be a minimum of 10 dB below the appropriate level in the new table.

(13) Concern was expressed by several State noise enforcing agencies about the seeming stringency of the wind measurement requirements. Their practical experience has indicated that the maximum wind velocities specified can be viewed rather loosely with no detrimental effects to noise measurements. With this in mind, it was suggested that extremely accurate wind measuring devices, such as anemometers, while desirable, were not always necessary.

In view of the above, the wind measurement requirements have been reworded to reflect a wider latitude insofar as an absolute upper wind velocity limit is concerned.

(14) One State enforcing agency expressed the desire to be able to measure noise emissions with already fallen snow on the ground. Without this ability, they stated, enforcement efforts within their State would be severely curtailed.

Data were submitted to the docket which indicate that snow is generally a

sound absorptive material. Accordingly, it could be expected to attenuate measured truck noise. Realizing this, if an enforcement agency still wishes to make measurements, they are free to do so and not be in jeopardy of unduly penalizing motor carriers. However, no correction factor can be applied for measurements made under these conditions since the amount of absorption attributable to snow varies so widely (e.g., from hard frozen to loose powder) as to preclude a single correction factor.

(15) Several respondents asked that §§ 325.35 and 325.55 be modified to make it clear that measurements were prohibited under any conditions of precipitation.

Since this was the original intention of the proposed language of the two sections, they have been modified to make this point clear.

(16) Several commenters requested a clarification as to what orientations were acceptable, with regard to observer position relative to the vehicle and the sound level meter, when the sound level meter is being hand held. Since the publication of the Notice of Proposed Rule Making (NPRM) on this subject, it has been noted that several observer positions may be appropriate, depending on which sound level measuring system is being used. Accordingly, §§ 325.37 and 325.57 have been modified to allow any observer orientation that is recommended by the manufacturer of the sound level meter.

(17) Several commenters suggested that § 325.51(a) (1) and (2), dealing with microphone location heights relative to the ground, be clarified.

The Director concurs and has simplified the language of the section in an attempt to clarify its original intent.

(18) Several commenters requested that the 6 dB "rise and fall" that was proposed in § 325.39 be changed to be an 8 or 10 dB "rise and fall." These requests were generally tied to discussions of the 10 dB "down" ambient noise level requirements contained in § 325.35.

The 6 dB "rise and fall" requirement was added in an effort to ensure that when measurements are made, vehicles are spaced sufficiently far apart so that neither direct sound radiation nor reflections from vehicles, other than the one being measured, interfere with or enhance the measured noise levels. This requirement is a corollary to the open site clear zone requirements and acts to validate those requirements.

The 6 dB figure was determined by B. H. Sharp in *Methods on Highway Noise Measurement Sites*, March 1972,

Wyle Labs Report WSR 72-1. There is no reason to dispute the validity of the determination made therein nor is there any reason to tie the figure to the ambient noise level requirement. Accordingly, the figure remains at 6 dB.

(19) Considerable discussion centered around the proposal to reference microphone location points during stationary tests to the front face of the front bumper of the parked vehicle. Various alternative positions were suggested, such as on a line with the exhaust outlets, the rear face of the cab, and the midpoint of the vehicle's wheel base.

The proposed position was arbitrarily chosen as one which could be easily referenced and would therefore facilitate measurement procedures. The comments pointed out that, in some cases, this referencing system may result in less than maximum observed noise readings due to the sometimes distant location of the exhaust outlets relative to the vehicle's front bumper. Therefore, to ensure that the maximum readings envisioned by the test procedure are obtained, the referencing system has been changed to call out the vehicle's exhaust outlet(s).

(20) The New Jersey Turnpike Authority stated that they measure motor vehicle noise emissions with the microphone located 10±5 feet (3±1.5 m) above the ground. It was implied that they wished to continue this practice.

The noise survey data upon which the EPA based its Interstate Motor Carrier Noise Emission Standards were collected with microphone heights of 4±½ feet (1.2±.15 m) from the ground. In order to maintain the consistency of that standard, the microphone height originally proposed has been retained. Truck noise research sponsored by the U.S. DOT has shown that elevated microphones detect higher sound levels than those levels which would be detected at microphone heights of 4 feet (1.2 m). Thus, higher microphone elevations, if permitted, would impose a greater stringency than intended by the EPA standard.

(21) Several commenters, notably the U.S. EPA and the Illinois Environmental Protection Agency, expressed concern that the BMCS had, in effect, prescribed a standard by including a provision to allow vehicles equipped with fan clutches a "cool down" period, if necessary, prior to being subjected to a stationary noise emission test.

The provision was intended to eliminate the possibility of testing the vehicle with its radiator fan clutch engaged, as a result of a period of "hot soak" while

waiting to be tested. This condition is generally not encountered when the vehicle is operating.

The Director feels that, rather than prescribing a standard in this regard, he is merely prescribing the test procedures necessary to ensure compliance with the EPA standard when the technology identified by EPA as being available is utilized. The fan clutch has been identified as available noise abatement technology in the preamble to the EPA noise emission standard and in the EPA background document on the subject. Research sponsored by the U.S. DOT has shown rather conclusively that vehicles equipped with a fan clutch have their fans operating only 1 to 3 percent of the time the vehicle is in operation. (Accordingly, a substantial noise benefit is realized; see 40 FR 8658, February 28, 1975, for a further discussion of fan clutches.)

The exemption was proposed only for the stationary test since it is likely that during this test the fan clutch will engage. Vehicles waiting in a line at, say a weigh station, following high speed travel prior to arrival at the weigh station, are likely to be in a "hot soak" condition. Ram air across the radiator is absent and thermal loads on the engine cooling system will be high for this short period of time. Under these conditions, the fan may engage. If the vehicle were then subjected to a stationary test, which is likely to occur immediately after the vehicle is weighed, it is possible that, with the fan engaged, the vehicle would fail a test that it would otherwise pass, due to high fan noise. Such a situation is not compatible with the intent of the EPA standard since the manufacturer or the operator would have applied the technology available to him in this area, only to be penalized. If, after the prescribed 10-minute cool-down period, the vehicle still fails to comply, it is safe to assume that the fan clutch is out of adjustment or that another source of noise is excessive. Such failure to comply with the standard after cool-down shall be considered noncompliance.

The wording of the fan clutch provision has been modified to make it clear that any engine speed may be used to cool the engine down. This rewording should obviate the need for a cool down period longer than that initially proposed.

Subsequent discussions with officials of the U.S. EPA have clarified the logic, intent and authority of the proposed section. Agreement has been reached that the sections as included herein do not

intrude upon the authority of EPA to set noise emission standards. However, to ensure the complete integrity of the EPA standards, EPA intends to amend their standard as soon as possible to provide specifically for use of fan clutches. The fan clutch provision applies only to the stationary test. No exemption or re-test provisions apply to the drive-by tests.

In view of the above, the Bureau feels compelled to retain this provision. The provision does not, however, include a waiver for radiator shutters, nor was one intended. Radiator shutters tend to increase a vehicle's overall noise level when they are closed. No data have been submitted to indicate that noise reduction benefits result from the use of radiator shutters. To the contrary, they tend to cause additional fan noise except when they are open.

(22) Several commenters suggested modifications to the proposed stationary test procedure to make it clear that: 1) the engine should be "rapidly" accelerated in neutral gear at wide open throttle; 2) tests could be made with the microphone located on either side of the vehicle; and 3) stationary tests on gasoline powered vehicles may be invalid due to excessive governor overshoot.

The first two points listed above appear to be valid, and, therefore, have been included in this final rule. The last point is not a valid one. The test data collected by the Society of Automotive Engineers (SAE) and others, taken to verify the repeatability and validity of the stationary test, included numerous gasoline engine vehicles. The peak readings obtained from those vehicles, during stationary tests, as well as the readings obtained from diesel engine vehicles, were equally considered by the EPA when arriving at the maximum allowable value for the stationary test. Accordingly, the high governor overshoot problem attributable to some gasoline engine vehicles has already been factored into the standard.

(23) Several respondents requested that the range of allowable measurement distances be expanded from 35 to 83 feet (10.7 to 25.3 m) to 26 to 89 feet (7.9 to 30.3 m).

For reasons outlined in the previous discussion on site characteristics (point No. 11 in this discussion), the Director has declined to expand the originally proposed limits. Should further data become available in the future which will verify the validity of measuring at these other distances without being too lenient or too stringent, the Director will reconsider this issue.

(24) Several respondents challenged the validity of the 2 dB correction factor for ground surfaces. Others proposed that measurements be made only at sites meeting the stringent requirements of the SAE J336 test procedure.

In both the preamble to the EPA final rule on the Interstate Motor Carrier Noise Emission Standards (39 FR 38208, October 29, 1975) and in the EPA Background Document for Interstate Motor Carrier Noise Emission Regulations (October 1974, EPA 550/9-74-017, p. 36-37), the EPA clearly states that the final maximum allowable values for the stationary and for highway operations tests were based on the assumption that the former test would be conducted on a "hard" site, and that the latter tests would be conducted at "soft" grassy sites. The documents then state that the differences between the allowable stationary test noise level and the low speed highway operations test level are attributable to site variations, and that both levels would be the same if implemented at identical sites. The BMCS enforcement procedures merely reflect this fact and, therefore, the inclusion of a ground-surface correction factor is still deemed appropriate.

(25) One respondent pointed out the fact that under the proposed wording of § 325.91, exhaust-gas driven unloading systems would be prohibited since they employed an exhaust system cutout. It was requested that these types of cutouts be allowed.

The EPA standard on this subject obviously was not intended to prohibit exhaust-gas driven unloading systems. Accordingly, § 325.91 has been modified to make it clear that their continued use is not prohibited.

(26) One respondent asked that proposed § 325.93, dealing with visual tire inspections, be dropped since it was felt to be burdensome on carriers and manufacturers.

The BMCS is not at liberty to eliminate standards promulgated by the EPA under the provisions of the Noise Control Act. Accordingly, proposed § 325.93 has been retained.

ENVIRONMENTAL AND ECONOMIC IMPACT

Pursuant to the requirement of the National Environmental Policy Act (42 USC 4321 et seq.) and Executive Order 11821, Inflation Impact Statements, dated November 27, 1974, the Director has considered both the economic and environmental impacts of these regulations and determined them to be nega-

tive. This is the case since the regulations impose no new substantive requirements on the motor carrier industry. Rather, the regulations specified herein merely detail the measurement methodologies that must be followed in order to implement the Interstate Motor Carrier Noise Emission Standards issued by the EPA at 40 CFR 302.

The EPA extensively considered both the economic and environmental impacts attendant to motor carrier noise emission standards in their Background Document for Interstate Motor Carrier Noise Emission Regulations, October 1974, EPA-550/9-74-017. That document should be consulted for a detailed discussion of the costs and benefits resulting from the EPA standards.

The BMCS has analyzed the costs attributable to its enforcement efforts in this area and again has determined them to have a negative impact. Bureau Safety Investigators, will add this function to their responsibilities. Approximately 10 new positions are envisioned, at this time, for noise enforcement purposes. Accordingly, manpower costs will be somewhat increased.

Equipment costs associated with the Federal enforcement effort have been largely absorbed during another related Bureau activity. As a consequence of the Bureau's recently promulgated in-cab noise level regulations (40 CFR 393.94), the Bureau procured sound level measurement systems, calibrators, and tripods. Therefore, new equipment costs associated with the exterior noise emission enforcement effort will not increase significantly.

ENFORCEMENT

As stated in the preamble to the proposed rule on this subject, the Bureau anticipates that it will conduct a program of enforcing the noise emission standards through the same techniques that are used to enforce the Federal Motor Carrier Safety Regulations (FMCSR). Inspection and surveillance of motor carriers will be carried out through terminal surveys and equipment inspection and driver-equipment compliance checks at roadside sites. Under the Noise Control Act, a violation of an EPA Interstate Motor Carrier Noise Emission Standard gives rise to the possibility of imposing sanctions under Section 11 of the Act. The sanctions include criminal prosecution of knowing or willful violators, in which the maximum sentence may not exceed a fine of \$25,000 per day, imprisonment for 1 year, or both, in the case

of first offenders, and a fine of \$50,000 per day, imprisonment for 2 years, or both, in the case of subsequent offenses. In addition, Section 11 authorizes the United States to secure an injunction against future violations in the appropriate United States District Court and permits the Administrator of the EPA, after notice and the opportunity for hearing, to issue cease-and-desist orders against violators.

Section 18(a) of the Noise Control Act clearly gives to the EPA the statutory authority to promulgate regulations setting limits on noise emissions resulting from the operation of motor carriers engaged in interstate commerce. The EPA has clearly defined the scope of its authority, in its final rule on this subject, to include all the vehicles, having a GVWR or a GCWR greater than 10,000 pounds (4,536 kg.), which are operated by motor carriers who engage in interstate commerce. This authority extends to both the intrastate and interstate operations of interstate motor carriers.

Section 18(b) of the Act authorizes the Secretary of Transportation to carry out the regulations for ensuring compliance with EPA noise emission standards "... through the use of his powers and duties of enforcement and inspection authorized by the Interstate Commerce Act and the Department of Transportation Act."

Since the scope of the EPA standard includes both the intrastate and interstate operations of interstate motor carriers, this section, in turn, expands the authority of the BMCS to allow active regulation of all the operations of interstate motor carriers, insofar as noise emissions are concerned.

The basic "powers and duties" referred to in section 220 of the Interstate Commerce Act, 49 U.S.C. 320, section 220, requires motor carriers to submit their properties and documents for inspection and examination by designated special agents of the Department of Transportation's Federal Highway Administration. This is the statutory basis for § 325.13 of these rules. Section 220 also authorizes the Department of Transportation to require periodic and special reports from motor carriers subject to the Department's jurisdiction. It is on this basis that the Bureau now requires motor carriers whose equipment is found to be defective during a driver-equipment compliance check to make a report to the Bureau certifying that repairs have been

made (see 49 CFR 396.5). The Bureau will adopt a similar procedure in the case of motor vehicles which are found to be in violation of the noise emission standards.

The use by the Bureau of the administrative enforcement procedures described above, does not limit or restrict the administrative procedures or sanctions that a State or political subdivision thereof may employ in carrying out its motor carrier noise emission regulatory program, even after the effective date of the EPA standards and the Department of Transportation's regulations for implementing those standards. Section 18(c) of the Noise Control Act provides that after the Federal regulations have become effective, "... no State or political subdivision thereof may adopt or enforce any standard applicable to the same operation of such motor carrier unless such standard is identical to a standard applicable to noise emissions resulting from such operation prescribed by any regulation under this section." It is the position of the Bureau that, while the "preemption" provisions of Section 18 (c) require States and their political subdivisions that have not secured a special variance to apply the criteria and measurement methodologies as are specified in Federal regulations to determine whether a motor vehicle is in conformity with noise emission standards, once a violation is detected, the State or local government may proceed to impose sanctions or take other corrective action in accordance with its own law. Thus, for example, a State could, if it wished, bring a civil penalty proceeding against a violator, notwithstanding the fact that, under Federal law, the violation is a crime. Similarly, a State could, if its law permits, impound equipment found in violation of the noise emission standards, even though Federal law does not provide for impoundment as a sanction.

The rules finalized herein do not explicitly refer to the matters discussed here under the heading of "Enforcement." This is the case because the resolution of issues relating to the imposition of sanctions after violations of the noise emission standards are detected is a function of statutory construction rather than regulatory issuance. The discussion is included at this point in order to give interested persons insight into the Bureau's current thinking on these important issues.

In consideration of the foregoing, the Director of the Bureau of Motor Carrier Safety is amending Subchapter A of

Chapter III in title 49, CFR, by adding a new part 325, reading as set forth below.

This regulation is issued under the authority of Section 18 of the Noise Control Act of 1972, 42 U.S.C. 4917, the delegation of authority by the Secretary of Transportation at 49 CFR 1.48(p), and the delegation of authority by the Federal Highway Administrator at paragraph 7, Chapter 7, Part I of FHWA Order 1-1.

Issued on September 8, 1975.

ROBERT A. KAYE,
Director, Bureau of
Motor Carrier Safety.

Subpart A—General Provisions

- Sec.
325.1 Scope of the rules in this part.
325.3 Effective date.
325.5 Definitions.
325.7 Allowable Noise Levels.
325.9 Measurement Tolerances.

Subpart B—Administrative Provisions

- 325.11 Issuance, amendment, and revocation of the rules in this Part.
325.13 Inspection and examination of motor vehicles.

Subpart C—Instrumentation

- 325.21 Scope of the rules in this subpart.
325.23 Types of measurement systems which may be used.
325.25 Calibration of measurement systems.
325.27 Use of a windscreen.

Subpart D—Measurement of Noise Emissions; Highway Operations

- 325.31 Scope of rules in this subpart.
325.33 Site characteristics; highway operations.
325.35 Ambient conditions; highway operations.
325.37 Location and operation of sound level measurement systems; highway operations.
325.39 Measurement procedures; highway operations.

Subpart E—Measurement of Noise Emissions; Stationary Test

- 325.51 Scope of the rules in this subpart.
325.53 Site characteristics; stationary test.
325.55 Ambient conditions; stationary test.
325.57 Location and operation of sound level measurement systems; stationary test.
325.59 Measurement procedure; stationary test.

Subpart F—Correction Factors

- 325.71 Scope of the rules in this subpart.
325.73 Microphone distance correction factors.
325.75 Ground surface correction factors.
325.77 Computation of open site requirements—nonstandard sites.
325.79 Application of correction factors.

Subpart G—Exhaust Systems and Tires

- 325.91 Exhaust systems.
325.93 Tires.

AUTHORITY: sec. 18, 86 Stat. 1234, 1249-1250, 42 U.S.C. 4917.

Subpart A—General Provisions

§ 325.1 Scope of the rules in this part.

(a) The rules in this Part prescribe procedures for inspection, surveillance, and measurement of motor vehicles and motor vehicle equipment operated by motor carriers to determine whether those vehicles and that equipment conform to the Interstate Motor Carrier Noise Emission Standards of the Environmental Protection Agency, 40 CFR Part 202.

(b) Except as provided in paragraph (c) of this section, the rules in this Part apply to motor carriers engaged in interstate commerce. The rules apply at any time or under any condition of highway grade, load, acceleration or deceleration.

(c) The rules in this Part do not apply to—

(1) A motor vehicle that has a Gross Vehicle Weight Rating (GVWR) of 10,000 pounds (4,536 kg.) or less;

(2) A combination of motor vehicles that has a Gross Combination Weight Rating (GCWR) of 10,000 pounds (4,536 kg.) or less;

(3) The sound generated by a warning device, such as a horn or siren, installed in a motor vehicle, unless such device is intentionally sounded in order to preclude an otherwise valid noise emission measurement;

(4) An emergency motor vehicle, such as a fire engine, an ambulance, a police van, or a rescue van, when it is responding to an emergency call;

(5) A snow plow in operation; or

(6) The sound generated by auxiliary equipment which is normally operated only when the motor vehicle on which it is installed is stopped or is operating at a speed of 5 miles per hour (8 kph) or less, unless such device is intentionally operated at speeds greater than 5 mph (8 kph) in order to preclude an otherwise valid noise measurement. Examples of that type of auxiliary equipment include, but are not limited to, cranes, asphalt, spreaders, ditch diggers, liquid or slurry pumps, auxiliary air compressors, welders, and trash compactors.

§ 325.3 Effective date.

The rules in this part are effective on October 15, 1975.

§ 325.5 Definitions.

(a) Statutory definitions. All terms defined in the Noise Control Act of 1972 (Pub. L. 92-574, 86 Stat. 1234) are used as they are defined in that Act.

(b) Definitions in standards. All terms defined in § 202.10 of the Interstate Motor Carrier Noise Emission Standards, 40 CFR 202.10, are used as they are defined in that section.

(c) Additional definitions.

(1) "Hard test site" means any test site having the ground surface covered with concrete, asphalt, packed dirt, gravel, or similar reflective material for more than 1/2 the distance between the microphone target point and the microphone location point.

(2) "Soft test site" means any test site having the ground surface covered with grass, other ground cover, or similar absorptive material for 1/2 or more of the distance between the microphone target point and the microphone location point.

(3) "Ground cover" means any of various low, dense-growing plants, such as ivy, myrtle, low weeds, or brush.

(4) "Traffic railing" means any longitudinal highway traffic barrier system installed along the side or median of a highway. For the purpose of this part, a traffic railing must have at least 35 percent of its vertical height, from the ground surface to the top of the railing, open to free space in order to qualify as an acceptable object within a noise measurement test site. Further, for the purposes of this part, posts or other discrete supports shall be ignored when ascertaining open free space.

(5) "Relatively flat" when used to describe a noise measurement site means a site which does not contain significant concave curvatures or slope reversals that may result in the focusing of sound waves toward the microphone location point.

§ 325.7 Allowable noise levels.

Motor vehicle noise emissions, when measured according to the rules of this part, shall not exceed the values specified in Table 1.

§ 325.9 Measurement tolerances.

(a) Measurement tolerances will be allowed to take into account the effects of the following factors:

(1) The consensus standard practice of reporting field sound level measurements to the nearest whole decibel.

(2) Variations resulting from commercial instrument tolerances.

(3) Variations resulting from the topography of the noise measurement site.

(4) Variations resulting from atmospheric conditions such as wind, ambient temperature, and atmospheric pressure.

(5) Variations resulting from reflected sound from small objects allowed within the test site.

(6) The interpretation of the effects of the above cited factors by enforcement personnel.

(b) Measurement tolerances shall not exceed 3 decibels for a given measurement.

Subpart D—Administrative Provisions

§ 325.11 Issuance, amendment, and revocation of the rules in this part.

The procedures specified in Part 380 of this Chapter for the issuance, amendment, or revocation of the Federal Motor Carrier Safety Regulations apply to rule-making proceedings for the issuance, amendment, or revocation of the rules in this part.

§ 325.13 Inspection and examination of motor vehicles.

(a) Any special agent of the Federal Highway Administration (designated in Appendix B to Subchapter B of this Chapter) is authorized to inspect.

TABLE 1.—Maximum Permissible Sound Level Readings [dcelbel(A)]¹

If the distance between the microphone location point and the microphone target point is—	Highway operations test				Stationary tests	
	Soft site		Hard site		Soft site	Hard site
	35 mi/h or less	Above 35 mi/h	35 mi/h or less	Above 35 mi/h		
35 ft (10.7 m) or more but less than 40 ft (11.9 m).....	89	93	91	95	89	91
39 ft (11.9 m) or more but less than 42 ft (12.8 m).....	88	92	90	94	88	90
43 ft (13.1 m) or more but less than 48 ft (14.6 m).....	87	91	89	93	87	89
48 ft (14.6 m) or more but less than 58 ft (17.7 m).....	85	90	88	92	85	88
58 ft (17.7 m) or more but less than 70 ft (21.3 m).....	85	89	87	91	85	87
70 ft (21.3 m) or more but less than 83 ft (25.3 m).....	84	88	86	90	84	86

¹ The speeds shown refer to measurements taken at sites having speed limits as indicated. These speed limits do not necessarily have to be posted.

² This table is based on motor carrier noise emission requirements specified in 40 CFR 202.20 and 40 CFR 202.21.

examine, and test a motor vehicle operated by a motor carrier in accordance with the procedures specified in this Part for the purpose of ascertaining whether the motor vehicle and equipment installed on the motor vehicle conforms to the Interstate Motor Carrier Noise Emission Standards of the Environmental Protection Agency, 40 CFR Part 202.

(b) A motor carrier, its officers, drivers, agents, and employees must, at any time, submit a motor vehicle used in its operations for inspection, examination, and testing for the purpose of ascertaining whether the motor vehicle and equipment installed on it conforms to the Interstate Motor Carrier Noise Emission Standards of the Environmental Protection Agency, 40 CFR Part 202.

Subpart C—Instrumentation

§ 325.21 Scope of the rules in this subpart.

The rules in this subpart specify criteria for sound level measurement systems which are used to make the sound level measurements specified in Subpart D and Subpart E of this part.

§ 325.23 Type of measurement systems which may be used.

The sound level measurement system must meet or exceed the requirements of American National Standard Specification for Sound Level Meters (ANSI S1.4-1971), approved April 27, 1971, issued by the American National Standards Institute,¹ throughout the applicable frequency range for either:

- (a) A Type 1 sound level meter;
- (b) A Type 2 sound level meter; or
- (c) A Type S sound level meter which has—

- (1) A-weighting frequency response;
- (2) Fast dynamic characteristics of its indicating instrument; and
- (3) A relative response level tolerance consistent with those of either a Type 1 or Type 2 sound level meter, as specified in Section 3.2 of ANSI S1.4-1971.

§ 325.25 Calibration of measurement systems.

(a) (1) The sound level measurement system must be calibrated and appropriately adjusted at one or more frequencies in the range from 250 to 1,000 Hz at the beginning of each series of measurements and at intervals of 8-15 minutes thereafter until it has been established that the sound level measurement system has not drifted from its calibrated level. Once this fact has been established, calibrations may be made at intervals of once every hour.

¹ Copies of the specification may be secured from the American National Standards Institute, 1430 Broadway, New York, New York, 10018.

(2) The sound level measurement system must be checked periodically by its manufacturer, a representative of its manufacturer, or a person of equivalent special competence to verify that its accuracy meets the manufacturer's design criteria.

(b) An acoustical calibrator of the microphone coupler type designed for the sound level measurement system in use shall be used to calibrate the sound level measurement system in accordance with paragraph (a) of this section. The calibrator must meet or exceed the accuracy requirements specified in the American National Standards Institute Standard *Methods for Measurements of Sound Pressure Levels*, (ANSI S1.13-1971) for calibrators for field type measurements.

§ 325.27 Windcreens.

A properly installed windscreen, of the type recommended by the manufacturer of the Sound Level Measurement System, shall be used during the time that noise emission measurements are being taken.

Subpart D—Measurement of Noise Emissions Highway Operations

§ 325.31 Scope of the rules in this subpart.

The rules in this subpart specify conditions and procedures for measurement of the sound level generated by a motor vehicle engaged in a highway operation for the purpose of ascertaining whether the motor vehicle conforms to the Standards for Highway Operations set forth in 40 CFR 202.20.

§ 325.33 Site characteristics: highway operations.

(a) Measurement shall be made at a test site which is adjacent to, and includes a portion of, a traveled lane of a public highway. A microphone target point shall be established on the centerline of the traveled lane of the highway, and a microphone location point shall be established on the ground surface not less than 35 feet (10.7 m) or more than 83 feet (25.3 m) from the microphone target point and on a line that is perpendicular to the centerline of the traveled lane of the highway and that passes through the microphone target point. In the case of a standard test site, the microphone location point is 50 feet (15.2 m) from the microphone target point. Within the test site is a triangular measurement area. A plan view diagram of a standard test site, having an open site within a 50-foot (15.2 m) radius of both the microphone target point and the microphone location point, is shown in Figure 1. Measurements may be made at a test site having smaller or greater dimensions in accordance with the rules in Subpart F of this Part.

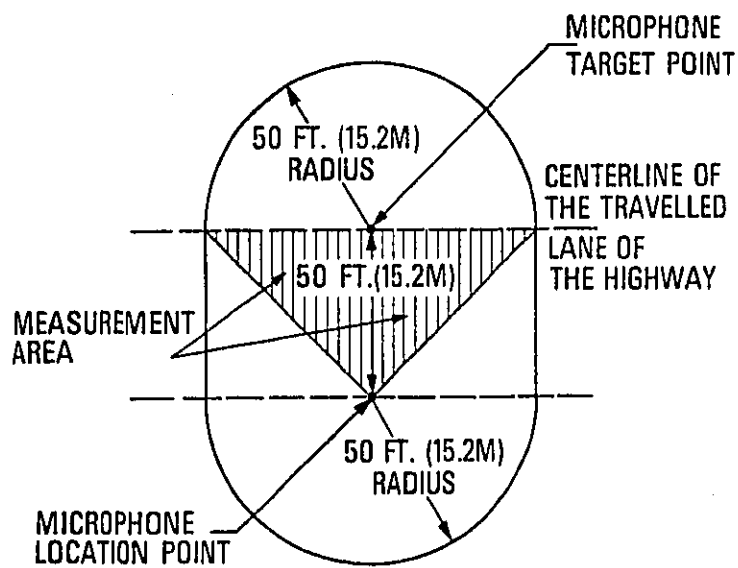

Figure 1
 STANDARD TEST SITE;
 HIGHWAY OPERATIONS

(b) The test site must be an open site, essentially free of large sound-reflecting objects. However, the following objects may be within the test site, including the triangular measurement area:

(1) Small cylindrical objects such as fire hydrants or telephone or utility poles.

(2) Rural mailboxes.

(3) Traffic railings of any type of construction except solid concrete barriers (see § 325.5(c)(4)).

(4) One or more curbs having a vertical height of 1 foot (.3 m) or less.

(c) The following objects may be within the test site if they are outside of the triangular measurement area of the site:

(1) Any vertical surface (such as billboard), regardless of size, having a lower edge more than 15 feet (4.6 m) higher than the surface of the traveled lane of the highway.

(2) Any uniformly smooth sloping surface slanting away from the highway (such as a rise in grade alongside the highway) with a slope that is less than 45 degrees above the horizontal.

(3) Any surface slanting away from the highway that is 45 degrees or more and not more than 90 degrees above the horizontal, if all points on the surface are more than 15 feet (4.6 m) above the surface of the traveled lane of the highway.

(d) The surface of the ground within the measurement area must be relatively flat (see § 325.5(c)(5)). The site shall be a "soft" test site. However, if the site is determined to be "hard," the correction factor specified in § 325.75(a) of this part shall be applied to the measurement.

(e) The traveled lane of the highway within the test site must be dry, paved with relatively smooth concrete or asphalt, and substantially free of—

(1) Holes or other defects which would cause a motor vehicle to emit irregular tire, body, or chassis impact noise; and

(2) Loose material, such as gravel or sand.

(f) The traveled lane of the highway on which the microphone target point is situated must not pass through a tunnel

or underpass located within 200 feet (61 m) of that point.

§ 325.35 Ambient conditions; highway operations.

(a) (1) *Sound.* The ambient A-weighted sound level at the microphone location point shall be measured, in the absence of motor vehicle noise, with fast meter response using a sound level measurement system that conforms to the rules in § 325.23 of this Part.

(2) The measured ambient level must be 10 dB(A) or more below that level specified in § 325.9, Table 1, which corresponds to the maximum permissible sound level reading which is applicable at the test site at the time of testing.

(b) *Wind.* The wind velocity at the test shall be measured at the beginning of each series of noise measurements and at intervals of 5-15 minutes thereafter until it has been established that the wind velocity is essentially constant. Once this fact has been established, wind velocity measurements may be made at intervals of once every hour. Noise measurements may only be made if the measured wind velocity is 12 mph (19.3 kph) or less. Gust wind measurements of up to 20 mph (32.3 kph) are allowed.

(c) *Precipitation.* Measurements are prohibited under any condition of precipitation, however, measurements may be made with snow on the ground. The ground surface within the measurement area must be free of standing water.

§ 325.37 Location and operation of sound level measurement systems; highway operations.

(a) The microphone of a sound level measurement system that conforms to the rules in § 325.23 of this Part shall be located at a height of not less than 2 feet (.6 m) nor more than 6 feet (1.8 m) above the plane of the roadway surface and not less than 3½ feet (1.1 m) and not more than 4½ feet (1.4 m) above the surface on which the microphone stands.

(b) (1) When the sound level measurement system is hand-held or is otherwise monitored by a person located near its microphone, the holder must orient himself relative to the highway in a manner

consistent with the recommendation of the manufacturer of the sound level measurement system.

(2) In no case shall the holder or observer be closer than 2 feet (.6 m) from the system's microphone, nor shall he locate himself between the microphone and the vehicle being measured.

(c) The microphone of the sound level measurement system shall be oriented toward the traveled lane of the highway at the microphone target point at an angle that is consistent with the recommendation of the system's manufacturer. If the manufacturer of the system does not recommend an angle of orientation for its microphone, the microphone shall be oriented toward the highway at an angle of not less than 70 degrees and not more than perpendicular to the horizontal plane of the traveled lane of the highway at the microphone target point.

(d) The sound level measurement system shall be set to the A-weighting network and "fast" meter response mode.

§ 325.39 Measurement procedure; highway operations.

(a) In accordance with the rules in this subpart, a measurement shall be made of the sound level generated by a motor vehicle operating through the measurement area on the traveled lane of the highway within the test site, regardless of the highway grade, load, acceleration or deceleration.

(b) The sound level generated by the motor vehicle is the highest reading observed on the sound level measurement system as the vehicle passes through the measurement area, corrected, when appropriate, in accordance with the rules in Subpart F of this Part. (Table 1 in § 325.9 lists the range of maximum permissible sound level readings for various test conditions.) The sound level of the vehicle being measured must be observed to rise at least 6 dB(A) before the maximum sound level occurs and to fall at least 6 dB(A) after the maximum sound

level occurs in order to be considered a valid sound level reading.

Subpart E--Measurement of Noise Emissions Stationary Test

§ 325.51 Scope of the rules in this subpart.

(a) The rules in this subpart specify conditions and procedures for measuring the sound level generated by a vehicle when the vehicle's engine is rapidly accelerated from idle to governed speed at wide open throttle with the vehicle stationary, its transmission in neutral, and its clutch engaged, for the purpose of ascertaining whether the motor vehicle conforms to the Standard for Operation Under Stationary Test, 40 CFR 202.21.

(b) The rules in this subpart apply only to a motor vehicle that is equipped with an engine speed governor.

(c) Tests conducted in accordance with the rules of this subpart may be made on either side of the vehicle.

§ 325.53 Site characteristics; stationary test.

(a) (1) The motor vehicle to be tested shall be parked on the test site. A microphone target point shall be established on the ground surface of the site on the centerline of the lane in which the motor vehicle is parked at a point that is within 3 feet (.91 m) of the vehicle's exhaust system outlet(s). A microphone location point shall be established on the ground surface not less than 35 feet (10.7 m) and not more than 83 feet (25.3 m) from the microphone target point. Within the test site is a triangular measurement area. A plan view diagram of a standard test site, having an open site within a 50-foot (15.2 m) radius of both the microphone target point and the microphone location point, is shown in Figure 2.

(2) Measurements may be made at a test site having smaller or greater dimensions in accordance with the rules in Subpart F of this Part.

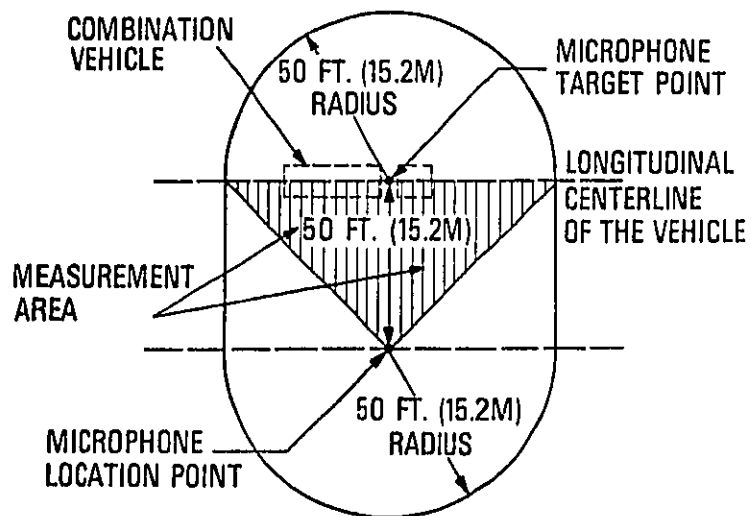

Figure 2
STANDARD TEST SITE;
STATIONARY TEST

(b) The test site must be an open site, essentially free of large sound-reflecting objects. However, the following objects may be within the test site, including the triangular measurement area:

- (1) Small cylindrical objects such as fire hydrants or telephone or utility poles.
- (2) Rural mailboxes.
- (3) Traffic railings of any type of construction except solid concrete barriers (see § 325.5(c)(4)).
- (4) One or more curbs having a height of 1 foot (3 m) or less.

(c) The following objects may be within the test site if they are outside of the triangular measurement area of the site:

(1) Any vertical surface, regardless of size (such as a billboard), having a lower edge more than 15 feet (4.6 m) above the ground.

(2) Any uniformly smooth surface slanting away from the vehicle with a slope that is less than 45 degrees above the horizontal.

(3) Any surface slanting away from the vehicle that is 45 degrees or more and not more than 90 degrees above the horizontal. If all points on the surface are more than 15 feet (4.6 m) above the surface of the ground in the test site.

(d) The surface of the ground within the measurement area must be relatively flat. (See § 325.5(c)(5)). The site shall be a "hard" site. However, if the site is determined to be "soft," the correction factor specified in § 325.75(b) of this Part shall be applied to the measurement.

§ 325.55 Ambient conditions; stationary test.

(a) **Sound.** The ambient A-weighted sound level at the microphone location point shall be measured in the absence of motor vehicle noise, with fast meter response using a sound level measurement system that conforms to the rules in § 325.23 of this Part. The measured ambient level must be 10 dB(A) or more below that level specified in § 325.9, Table 1, which corresponds to the maximum permissible sound level reading which is applicable at the test site at the time of testing.

(b) **Wind.** The wind velocity at the test site shall be measured at the beginning of each series of noise measurements and at intervals of 5-15 minutes thereafter until it has been established that the wind velocity is essentially constant. Once this fact has been established, wind velocity measurements may be made at intervals of once every hour. Noise measurements may only be made if the measured wind velocity is 12 mph (19.3 kph) or less. Gust wind measurements of up to 20 mph (32.2 kph) are allowed.

(c) **Precipitation.** Measurements are prohibited under any conditions of precipitation, however, measurements may

be made with snow on the ground. The ground within the measurement area must be free of standing water.

§ 325.57 Location and operation of sound level measurement system; stationary test.

(a) The microphone of a sound level measurement system that conforms to the rules in § 325.23 of this part shall be located at a height of not less than 2 feet (6 m) nor more than 8 feet (1.8 m) above the plane of the roadway surface and not less than 3½ feet (1.1 m) and not more than 4½ feet (1.4 m) above the surface on which the microphone stands.

(b) When the sound level measurement system is hand-held or otherwise monitored by a person located near its microphone, the holder must orient himself relative to the highway in a manner consistent with the recommendation of the manufacturer of the sound level measurement system. In no case shall the holder or observer be closer than 2 feet (6 m) from the system's microphone, nor shall he locate himself between the microphone and the vehicle being measured.

(c) The microphone of the sound level measurement system shall be oriented toward the vehicle at an angle that is consistent with the recommendation of the system's manufacturer. If the manufacturer of the system does not recommend an angle of orientation for its microphone, the microphone shall be oriented at an angle of not less than 70 degrees and not more than perpendicular to the horizontal plane of the test site at the microphone target point.

(d) The sound level measurement system shall be set to the A-weighting network and "fast" meter response mode.

§ 325.59 Measurement procedure; stationary test.

In accordance with the rules in this subpart, a measurement shall be made of the sound level generated by a stationary motor vehicle as follows:

(a) Park the motor vehicle on the test site as specified in § 325.53 of this subpart. If the motor vehicle is a combination (articulated) vehicle, park the combination so that the longitudinal centerlines of the towing vehicle and the towed vehicle or vehicles are in substantial alignment.

(b) Turn off all auxiliary equipment which is installed on the motor vehicle and which is designed to operate under normal conditions only when the vehicle is operating at a speed of 5 mph (8 kph) or less. Examples of such equipment include cranes, asphalt spreaders, liquid or slurry pumps, auxiliary air compressors, welders, and trash compactors.

(c) If the motor vehicle's engine radiator fan drive is equipped with a clutch or similar device that automatically

either reduces the rotational speed of the fan or completely disengages the fan from its power source in response to reduced engine cooling loads, park the vehicle before testing with its engine running at high idle or any other speed the operator may choose, for sufficient time but not more than 10 minutes, to permit the engine radiator fan to automatically disengage when the vehicle's noise emissions are measured under stationary test.

(d) With the motor vehicle's transmission in neutral and its clutch engaged, rapidly accelerate the vehicle's engine from idle to its maximum governed speed with wide open throttle. Return the engine's speed to idle.

(e) Observe the maximum reading on the sound level measurement system during the time the procedures specified in paragraph (d) of this section are followed. Record that reading. If the reading has not been influenced by extraneous noise sources such as motor vehicles operating on adjacent roadways.

(f) Repeat the procedures specified in paragraphs (d) and (e) of this section until the first two maximum sound level readings that are within 2dB(A) of each other are recorded. Numerically average those two maximum sound level readings. When appropriate, correct the average figure in accordance with the rules in Subpart F of this part.

(g) The average figure, corrected as appropriate, contained in accordance with paragraph (f) of this section, is the sound level generated by the motor vehicle for the purpose of determining whether it conforms to the Standard for Operation Under Stationary Test, 40 CFR 202.21. (Table 1 in § 325.0 lists the range of maximum permissible sound level readings for various test conditions.)

Subpart F—Correction Factors

§ 325.71 Scope of the rules in this subpart.

(a) The rules in this subpart specify correction factors which are added to, or subtracted from, the reading of the sound level generated by a motor vehicle, as displayed on a sound level measurement system, during the measurement of the motor vehicle's sound level emissions at a test site which is not a standard site.

(b) The purpose of adding or subtracting a correction factor is to equate

¹ Table 1, in § 325.0 is a tabulation of the maximum allowable sound level readings taking into account both the distance correction factors contained in § 325.73 and the ground surface correction factors contained in § 325.75.

the sound level reading actually generated by the motor vehicle to the sound level reading it would have generated if the measurement had been made at a standard test site.

§ 325.73 Microphone distance correction factors.¹

If the distance between the microphone location point and the microphone target point is other than 50 feet (15.2 m), the maximum observed sound level reading generated by the motor vehicle in accordance with § 325.39 of this part or the numerical average of the recorded maximum observed sound level readings generated by the motor vehicle in accordance with § 325.59 of this part shall be corrected as specified in the following table:

TABLE 2—DISTANCE CORRECTION FACTORS

If the distance between the microphone location point and the microphone target point is:	The value (dB(A)) to be applied to the observed sound level reading is—
35 feet (10.7 m) or more but less than 50 feet (15.2 m) --	-3
39 feet (11.9 m) or more but less than 43 feet (13.1 m) --	-2
43 feet (13.1 m) or more but less than 48 feet (14.6 m) --	-1
48 feet (14.6 m) or more but less than 58 feet (17.7 m) --	0
58 feet (17.7 m) or more but less than 70 feet (21.3 m) --	+1
70 feet (21.3 m) or more but less than 83 feet (25.3 m) --	+2

§ 325.75 Ground surface correction factors.¹

(a) Highway operations. When measurements are made in accordance with the rules in Subpart D of this part upon a test site which is "hard," a correction factor of 2 dB(A) shall be subtracted from the maximum observed sound level reading generated by the motor vehicle to determine whether the motor vehicle conforms to the Standards for Highway Operations, 40 CFR 202.30.

(b) Stationary Test. When measurements are made in accordance with the rules in Subpart E of this part upon a test site which is "soft," a correction factor of 2 dB(A) shall be added to the numerical average of the recorded maximum observed sound level readings generated by the motor vehicle to determine whether the motor vehicle conforms to the Standard for Operation Under Stationary Test, 40 CFR 202.21.

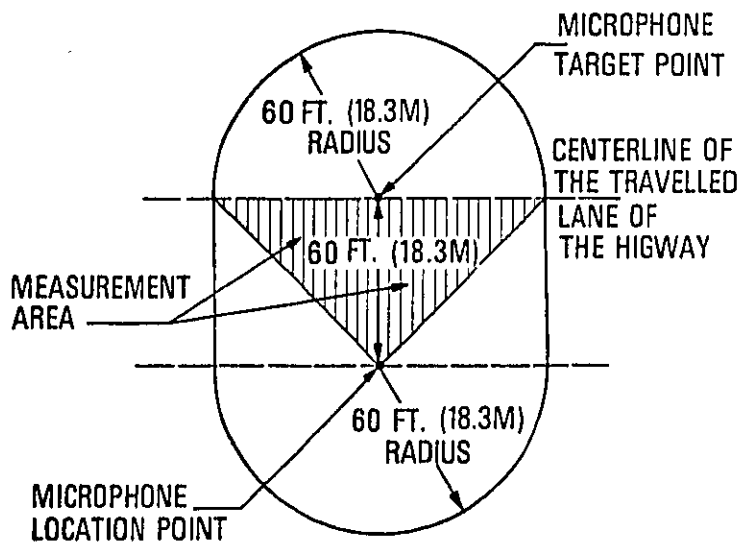

Figure 3
 NON-STANDARD TEST SITE;
 (60 FT (18.3M) DISTANCE BETWEEN
 MICROPHONE LOCATION AND TARGET POINTS)

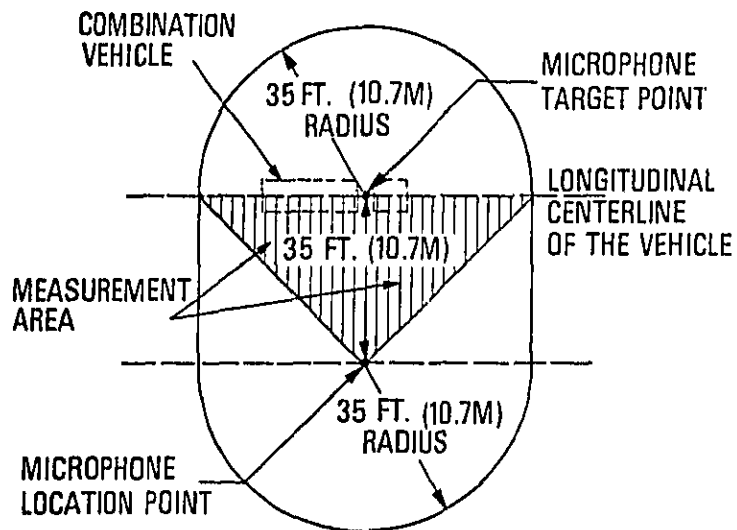

Figure 4
 NON-STANDARD TEST SITE;
 (35 FT.(10.7M) DISTANCE BETWEEN
 MICROPHONE LOCATION AND TARGET POINTS)

§ 325.77 Computation of open site requirements—nonstandard sites.

(a) If the distance between the microphone location point and the microphone target point is other than 50 feet (15.2 m), the test site must be an open site within a radius from both points which is equal to the distance between the microphone location point and the microphone target point.

(b) Plan view diagrams of nonstandard test sites are shown in Figures 3 and 4. Figure 3 illustrates a test site which is larger than a standard test site and is based upon a 60-foot (18.3 m) distance between the microphone location point and the microphone target point. (See § 325.79(b) (1) for an example of the application of the correction factor to a sound level reading obtained at such a site.) Figure 4 illustrates a test site which is smaller than a standard test site and is based upon a 35-foot (10.7 m) distance between the microphone location point and the microphone target point. (See § 325.79(b) (2) for an example of the application of the correction factor to a sound level reading obtained at such a site.)

§ 325.79 Application of correction factors.

(a) If two correction factors apply to a measurement they are applied cumulatively.

(b) The following examples illustrate the application of correction factors to sound level measurement readings:

(1) *Example 1—Highway operations.* Assume that a motor vehicle generates a maximum observed sound level reading of 86 dB(A) during a measurement in accordance with the rules in Subpart D of this Part. Assume also that the distance between the microphone location point and the microphone target point is 60 feet (18.3 m) and that the measurement area of the test site is acoustically "hard." The corrected sound level generated by the motor vehicle would be 85 dB(A), calculated as follows:

86 dB(A)	Uncorrected reading
+1 dB(A)	Distance correction factor
-2 dB(A)	Ground surface correction factor
85 dB(A)	Corrected reading

(2) *Example 2—Stationary test.* Assume that a motor vehicle generates maximum sound level readings which average 88 dB(A) during a measurement in accordance with the rules in Subpart E of this Part. Assume also that the distance between the microphone location point and the microphone target point is 35 feet (10.7 m), and that the measurement area of the test site is acoustically "soft." The corrected sound level generated by the motor vehicle would be 87 dB(A), calculated as follows:

88 dB(A)	Uncorrected average of readings
-3 dB(A)	Distance correction factor
+2 dB(A)	Ground surface correction factor
87 dB(A)	Corrected reading

Subpart G—Exhaust Systems and Tires

§ 325.91 Exhaust systems.

A motor vehicle does not conform to the visual exhaust system inspection requirements, 40 CFR 202.23, of the Interstate Motor Carrier Noise Emission Standards, if inspection of the exhaust system of the motor vehicle discloses that the system—

(a) Has a defect which adversely affects sound reduction, such as exhaust gas leaks or alteration or deterioration of muffler elements, (small traces of soot on flexible exhaust pipe sections shall not constitute a violation of this subpart);

(b) Is not equipped with either a muffler or other noise dissipative device, such as a turbocharger (supercharger driven by exhaust gases); or

(c) Is equipped with a cut-out, by-pass, or similar device, unless such device is designed as an exhaust gas driven cargo unloading system.

§ 325.93 Tires.

(a) Except as provided in paragraph (b) of this section, a motor vehicle does not conform to the visual tire inspection requirements, 40 CFR 202.23, of the Interstate Motor Carrier Noise Emissions Standards, if inspection of any tire on which the vehicle is operating discloses that the tire has a tread pattern composed primarily of cavities in the tread (excluding sipes and local chunking) which are not vented by grooves to the tire shoulder or circumferentially to each other around the tire.

(b) Paragraph (a) of this section does not apply to a motor vehicle operated on a tire having a tread pattern of the type specified in that paragraph, if the motor carrier who operates the motor vehicle demonstrates to the satisfaction of the Director of the Bureau of Motor Carrier Safety or his designee that either—

(1) The tire did not have that type of tread pattern when it was originally manufactured or newly remanufactured; or

(2) The motor vehicle generates a maximum sound level reading of 90 dB(A) or less when measured at a standard test site for highway operations at a distance of 50 feet (15.3 m) and under the following conditions:

(i) The measurement must be made at a time and place and under conditions specified by the Director or his designee.

(ii) The motor vehicle must be operated on the same tires that were installed on it when the inspection specified in paragraph (a) of this section occurred.

(iii) The motor vehicle must be operated on a highway having a posted speed limit of more than 35 mph (56.3 kph).

(iv) The sound level measurement must be made while the motor vehicle is operating at the posted speed limit.

[FR Doc. 78-24085 Filed 9-11-78; 8:45 am]